

The information and instructions contained in this document have been produced in accordance with alternative procedure to DOA EASA AP058. The technical content of this document refers to EASA ETSO Authorisation number EASA.210.818 and P/N S1840501-XX(X)(XX) under which the minor change or repair is covered.

## **KANNAD 406 AF-COMPACT**

### **Change in installation configuration**

#### **1. PLANNING INFORMATION**

##### **A. Effectivity**

This Service Bulletin is applicable to the KANNAD 406 AF-COMPACT ELTs (P/N S1840501-01) and KANNAD 406 AF-COMPACT (ER) ELTs (P/N S1840501-04) equipped with Programming Dongle (P/N S1820514-01) or Programming Dongle Assembly (P/N S1820514-06), manufactured by Safran Electronics & Defense Beacons SAS.

This Service Bulletin does not apply to any Emergency Locator Transmitter (ELT) other than the two listed above, even if the ELT is equipped with a Programming Dongle or Programming Dongle Assembly. The Programming Dongle and Programming Dongle Assembly can still be installed with all other ELTs manufactured by SED Beacons, except with the KANNAD 406 AF COMPACT ELTs cited above.

##### **B. Concurrent Requirement**

N/A

##### **C. Reason**

An issue has been reported to Safran Electronics & Defense Beacons concerning the transmission of some random bursts in maintenance code during valid distress transmissions.

Indeed, it appears that during distress transmission, some emissions may erroneously be encoded with a maintenance encoding instead of an operational one. Emissions with maintenance encoding are filtered by Cospas-Sarsat infrastructure and may not be visible by the Mission Control Center.

Fortunately, this defect is never permanent during a distress as distress bursts are still sent by the ELT at more or less regular intervals, but the distress signal may be interrupted and delayed, or disturb the rescue activities. In addition, this defect only affects the 406 MHz transmission addressed to Cospas-Sarsat, homing frequencies are not affected.

Therefore, there is a limited safety impact as the emergency services receive the distress burst. It is even possible that emergency services will consider the reception of maintenance codes.

After analysis, it was concluded that it can only occur in a specific installation configuration (programming dongle connected to the ELT during flight).

There are two installation configurations that lead to this issue:

- When the installation configuration includes a KANNAD 406 AF COMPACT ELT (P/N S1840501-01 or S1840501-04) with a Programming Dongle Assembly (P/N S1820514-06).
- When the installation configuration includes a KANNAD 406 AF COMPACT ELT (P/N S1840501-01 or S1840501-04) with a Programming Dongle (P/N S1820514-01).

**D. Description**

This Service Bulletin describes how to check the installation and, if necessary, change the installation in order to avoid random improper transmissions during ELT distress transmission. In case of a change of installation involving the removal of the Programming Dongle, this Programming Dongle can be kept and used as on-ground programming tool only.

The risk is classified as low taking into consideration the limited safety impact detailed in section C. Reason. Therefore, following the inspection, the aircraft affected by the specified installation configurations do not need to be grounded.

**E. Compliance**

Mandatory - Service Bulletin must be accomplished.

The installation configuration including a Programming Dongle or a Programming Dongle Assembly shall be modified as per instruction Section 3: Accomplishment instructions.

This Service Bulletin must be accomplished before March 18, 2027.

**F. Approval**

Following the application of this Service Bulletin, all installation configurations remain approved configurations.

**G. Manpower**

Inspection: Less than 1 minute once access is gained to the ELT.

Modification: 1 hour.

**H. Weight and Balance**

None.

**I. Electrical Load Data**

Not Changed.

**J. Software Accomplishment Summary**

Not applicable.

**K. References**

DOC07089 406 AF COMPACT Initial Installation Manual.

**L. Other Publications Affected**

As a consequence of the Service Bulletin issuance, the DOC08038 406 AF COMPACT Operation Manual and DOC07089 406 AF COMPACT Initial Installation Manual will be updated.

**M. Interchangeability**

One-way.

## 2. MATERIAL INFORMATION

### A. Material - Price and Availability

In case of an installation configuration including a Programming Dongle (P/N S1820514-01):

- DIN 12 Connector P/N S1820514-03.
- Price: free of charge.

In case of an installation configuration including a Programming Dongle Assembly (P/N S1820514-06):

- None, or DIN 12 Connector P/N S1820514-03, refer to section [3.C Changes to apply for installation including Programming Dongle Assembly \(P/N S1820514-06\)](#).
- Price: free of charge.

### B. Industry Support Information

If the installation configuration requires it (see [3.A Inspection of the Installation Configuration, page 4](#)), Safran Electronics & Defense Beacons will provide the DIN 12 connector free of charge and endorse the cost of transport subject to prior approval and instructions from Safran Electronics & Defense Beacons. The DIN 12 connector will be free of charge until March 18, 2027.

To receive a DIN 12 connector, contact an Authorized Partner (See [Appendix A: List of Authorized Partner](#)) and provide:

- The reference number of this Service Bulletin,
- The Part Number of the affected KANNAD 406 AF-COMPACT ELT,
- The serial number of the affected KANNAD 406 AF-COMPACT ELT,
- The serial number of the affected dongle.

The DIN 12 connector will be delivered free of charge by the Authorized Partner.

Any other cost related to this replacement such as removal, administrative, aircraft grounded, loss of earnings, etc. cannot be claimed to Safran Electronics & Defense Beacons SAS.

### C. Material Necessary for Each Component

Not applicable.

### D. Material Necessary for Each Spare

Not applicable.

### E. Re-identified Parts

Not applicable.

### F. Tooling - Price and Availability

Not applicable.

### 3. ACCOMPLISHMENT INSTRUCTIONS

**IMPORTANT: Verify the aircraft instructions. When a new ELT is installed without any Dongle in the installation configuration, the ELT needs to be reprogrammed systematically at a programming center or with a PR600. It is possible to use the removed Programming Dongle as an on-ground programming tool.**

#### A. Inspection of the Installation Configuration

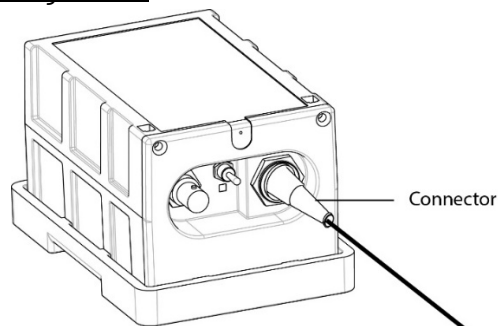

Figure 1: Connector Location

1. If the installation does not include any connector, the installation is correct and does not need to be modified.
2. If the installation includes a connector, refer to the connector label to find its Part Number:



- a. If the installation includes a **DIN 12 connector P/N S1820514-03**, the installation is correct and does not need to be modified.
- b. If the installation includes a **Programming Dongle P/N S1820514-01**, the Programming Dongle shall be replaced by a DIN 12 connector (P/N S1820514-03), following the procedure given in section [3.B Changes to apply for installation including Programming Dongle \(P/N S1820514-01\) page 5](#).
- c. If the installation includes a **Programming Dongle Assembly P/N S1820514-06**, remove the Programming Dongle Assembly of the installation following the procedure given in section [3.C Changes to apply for installation including Programming Dongle Assembly \(P/N S1820514-06\) page 6](#).

3. If the connector label is missing or unreadable:
  - a. Remove the small screw which holds the metallic body of the connector with a small flathead screwdriver.
  - b. Slide down the metallic body of the connector to remove it.
  - c. Open the small plastic plate.
  - d. If there is no small PCBA inside the connector, it is a DIN12 connector P/N S1820514-03. If there is a small PCBA inside the connector, it is a Programming Dongle P/N S1820514-01. Refer to Figure 2: DIN12 connector vs Programming Dongle.

Figure 2: DIN12 connector vs Programming Dongle



**B. Changes to apply for installation including Programming Dongle (P/N S1820514-01)**

1. Visually inspect that the antenna is correctly connected and that the ELT switch is set to “ARM” position.
2. Set the RCP switch to “RESET & TEST” to do a self-test:
  - a. The buzzer operates during the whole Self-test procedure.
  - b. After a few seconds, the test result is displayed with the LED as follows:  
One long flash indicates that the system is operational and that no error conditions were found.
3. Disconnect the Programming Dongle from the ELT.
4. Use a label printer to print out the coding information written on the Programming Dongle label.

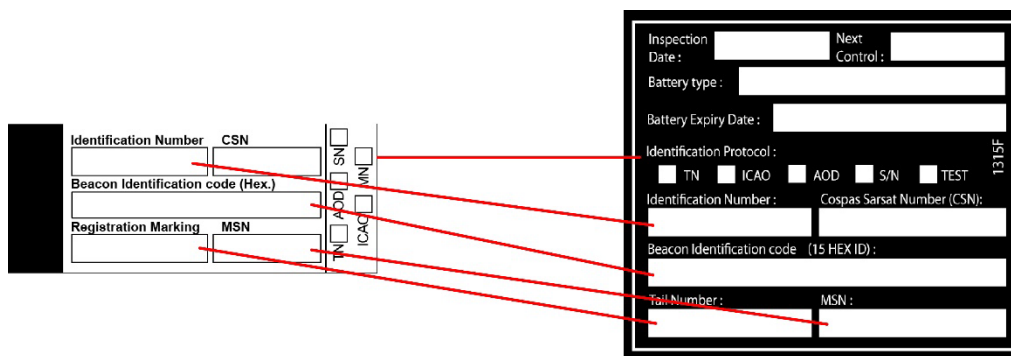

5. Stick the coding information labels onto the ELT rear label.  
**IMPORTANT: The CSN field of the ELT label shall not be changed.**
6. Desolder the Programming Dongle from its cable.

7. Solder a DIN 12 connector in place of the Programming Dongle by keeping the same wirings.  
NOTE: The wiring procedure is detailed in the DOC07089 KANNAD 406 AF COMPACT Initial Installation Manual, refer to Appendix B: Extract of the Initial Installation Manual for Wiring.
8. Connect the DIN 12 connector to the ELT.
9. Set the RCP switch to "RESET & TEST" to do another self-test:
  - a. The buzzer operates during the whole Self-test procedure.
  - b. After a few seconds, the test result is displayed with the LED as follows:  
One long flash indicates that the system is operational and that no error conditions were found.

### C. Changes to apply for installation including Programming Dongle Assembly (P/N S1820514-06)

1. Visually inspect that the antenna is correctly connected and that the ELT switch is set to "ARM" position.
2. Set the RCP switch to "RESET & TEST" to do a self-test:
  - a. The buzzer operates during the whole Self-test procedure.
  - b. After a few seconds, the test result is displayed with the LED as follows:  
One long flash indicates that the system is operational and that no error conditions were found.
3. Disconnect the Programming Dongle Assembly from the ELT and from the RCP cable.
4. Use a label printer to print out the coding information written on the Programming Dongle label.

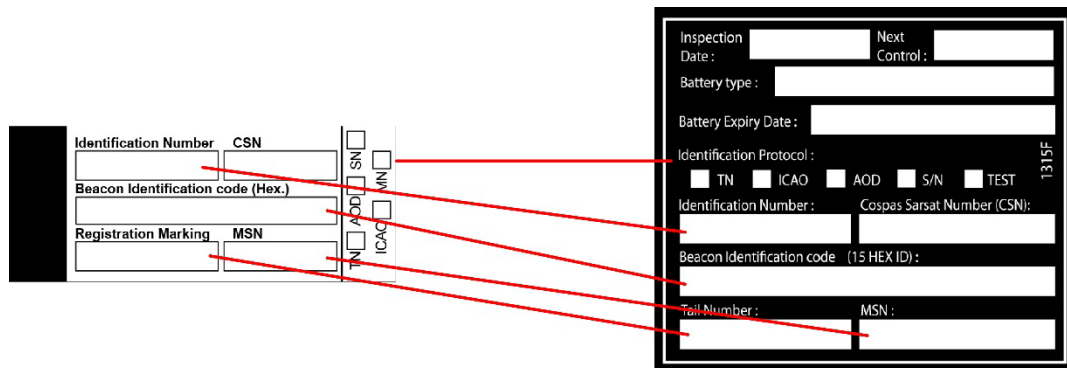

5. Stick the coding information labels onto the ELT rear label.

**IMPORTANT: The CSN field of the ELT label shall not be changed.**

6. Connect the DIN 12 connector from the RCP cable to the ELT.

NOTE: If the RCP cable is not long enough for connection, the procedure to make a new cable of the correct length is available in the DOC07089 KANNAD 406 AF COMPACT Initial Installation Manual, refer to [Appendix B: Extract of the Initial Installation Manual for Wiring](#). In this case, a DIN 12 connector can be ordered free of charge.

7. Connect the DIN 12 connector to the ELT.

8. Set the RCP switch to "RESET & TEST" to do another self-test:
  - a. The buzzer operates during the whole Self-test procedure.
  - b. After a few seconds, the test result is displayed with the LED as follows:  
One long flash indicates that the system is operational and that no error conditions were found.

For further information, please contact:

**Safran Electronics & Defense Beacons SAS Customer Service**

Zone Industrielle des Cinq Chemins

56520 GUIDEL

FRANCE

E-mail: [support.sar@beacons.safrangroup.com](mailto:support.sar@beacons.safrangroup.com)

Tel.: +33 2 97 02 49 00

## 4. Appendix A: List of Authorized Partner

---

### AMERICA

---

#### **Marte Updates & Avionics**

Av Olavo Fontoura, 1078, SECTOR D - LOTE 11 - ED  
 Marte Update  
 São Paulo SP 02012-021  
 Brazil  
[www.marteupdates.com.br](http://www.marteupdates.com.br)

#### **Aeromni Aerospace Inc.**

#46-21330 56 Avenue,  
 Langley, BC  
 V2Y 0E5  
 Canada  
[www.aeromni.com](http://www.aeromni.com)

#### **Maxcraft Avionics Ltd**

250 18799 Airport way,  
 Pitt Meadows, BC  
 V3Y 2B4  
 Canada  
[www.maxcraft.ca](http://www.maxcraft.ca)

#### **Mid-Canada Mod Center**

251 Jetliner Court, Hangar 53, PO Box 69,  
 Breslau, ON N0B1M0  
 Canada  
[www.midcanadamod.com](http://www.midcanadamod.com)

#### **Mid-Continent Instruments and Avionics**

9400 E. 34th Street North,  
 Wichita KS 67226  
 United States  
[www.mcico.com](http://www.mcico.com)

#### **Pacific Southwest Instruments**

1721 Railroad Street  
 Corona CA 92878  
 United States  
[www.psilabs.com](http://www.psilabs.com)

#### **Southern Cross Accessories**

5250 Nw 33 road ave.  
 STE-C Fort Lauderdale FL 33309  
 United States  
[www.scross.com](http://www.scross.com)

---

*ASIA-PACIFIC*

---

**Jet Aviation Australia Pty Ltd**

Hangar 149, Tom McDonald Drive, Airport  
Cairns QLD, 4870  
Australia  
[www.jetaviation.com](http://www.jetaviation.com)

**Aviation Radio Ltd**

18 George Bolt Street, Rongotai  
Wellington 6022  
New Zealand  
[www.aviationradio.co.nz](http://www.aviationradio.co.nz)

**Pacific Avionics Pty Ltd**

Hangar 480, 16 Miles Street, Bankstown Aerodrome,  
Sydney NSW 2200  
Australia  
[www.pacificavionics.com.au](http://www.pacificavionics.com.au)

**Guangzhou Hangxin Avionics Co., Ltd**

No. 2 Kexin Road, Tianhe District,  
Guangzhou 510665  
China  
[www.hangxin.com](http://www.hangxin.com)

**JR-Tech (Guangzhou) Co.,Ltd**

N° 7# Huahui Road, Huashan Industrial Zone, Huadu  
GUANGZHOU 510880  
China  
[www.jr-tech.com.cn](http://www.jr-tech.com.cn)

**Japan Aerospace Corp.**

2-3-8, Shiomi, Koto-ku  
Tokyo 136-0082  
Japan  
[www.j-aero.co.jp](http://www.j-aero.co.jp)

**Kaigai Corporation**

Tokyo Heliport Office  
4-7-45 Shin-Kiba, Koto-ku,  
Tokyo 136-0082  
Japan  
[www.kaigaibussan.co.jp/en/](http://www.kaigaibussan.co.jp/en/)

---

*EUROPE, MIDDLE EAST AND AFRICA*

---

**Scandinavian Avionics Denmark**

Stratusvej 9  
Billund DK-7190  
Denmark  
[www.scanav.com](http://www.scanav.com)

**Aerospace Management & Support**

Athens International Airport, Building 46, 5th km  
Spata-Loutsa Avenue  
Spata, Athens GR-19019  
Greece  
[www.amsaero.eu](http://www.amsaero.eu)

**Scandinavian Avionics Norway**

Generalmajor Mehrers Vei 1  
Gardermoen N-2062  
Norway  
[www.scanav.com](http://www.scanav.com)

**SEAM - Service Electronique Aviation Marine**

1070 rue du Lieutenant Parayre  
13858 AIX EN PROVENCE Cedex 3  
France  
<https://www.seam-avionic.com>

**Century Avionics CC**

Hangar M1, Gate 5, Lanseria Intl. Airport, Lanseria  
International Airport, PO Box 100,  
LANSERIA 1748  
South Africa  
[www.centuryavionics.co.za](http://www.centuryavionics.co.za)

**Total Technic**

Ataturk Havalimani Ici, Yeni Yerlesim Bolgesi,  
Bakirkoy Istanbul 34149  
Turkiye  
[www.total-technic.com](http://www.total-technic.com)

**Air Atlanta Aviaservices**

Unit 2, Meadowbrook Industrial Center, Maxwell  
Way  
Crawley, West Sussex RH10 9SA  
United Kingdom  
[www.aviaservices.com](http://www.aviaservices.com)

## 5. Appendix B: Extract of the Initial Installation Manual for Wiring

### A. Wiring diagram with RC100 RCP

#### Connect RCP to ELT

Refer to Figure 13: Wiring of 3-wire bundle between RC100 and ELT.

PAGE: 16

AUG 20/2013

**kannad**  
aviation

#### INITIAL INSTALLATION MANUAL KANNAD 406 AF-COMPACT / KANNAD 406 AF COMPACT ER

- Solder the DIN12 connector or Programming Dongle on the other side of the bundle (pins A, G, J):
  - Connect the wire from cathode (short leg) of LED to pin J of DIN12 connector;
  - Connect the wire from resistor to pin A of DIN12 connector;
  - Connect the wire from pin 2 of switch to pin G of DIN12 connector.
  - Connect the anode (long leg) of LED to pin 2 of switch.

*Figure 13: Wiring of 3-wire bundle between RC100 and ELT*

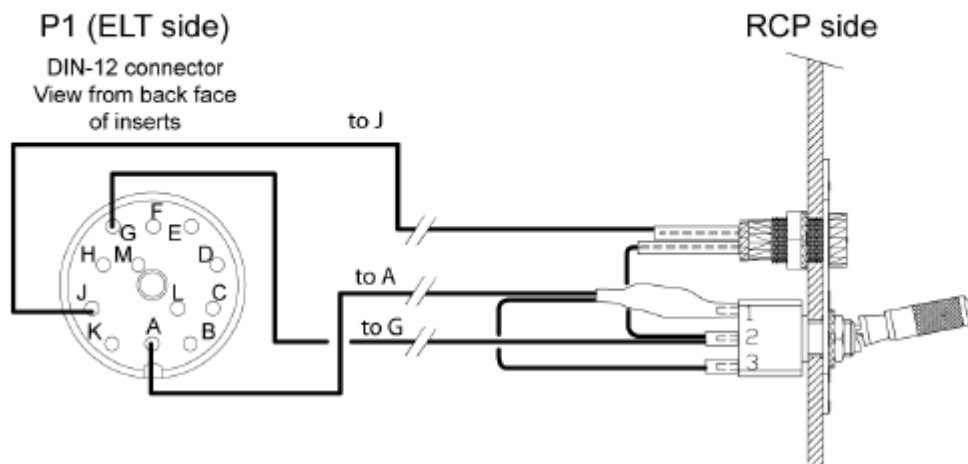

## B. Wiring diagram with RC102 RCP

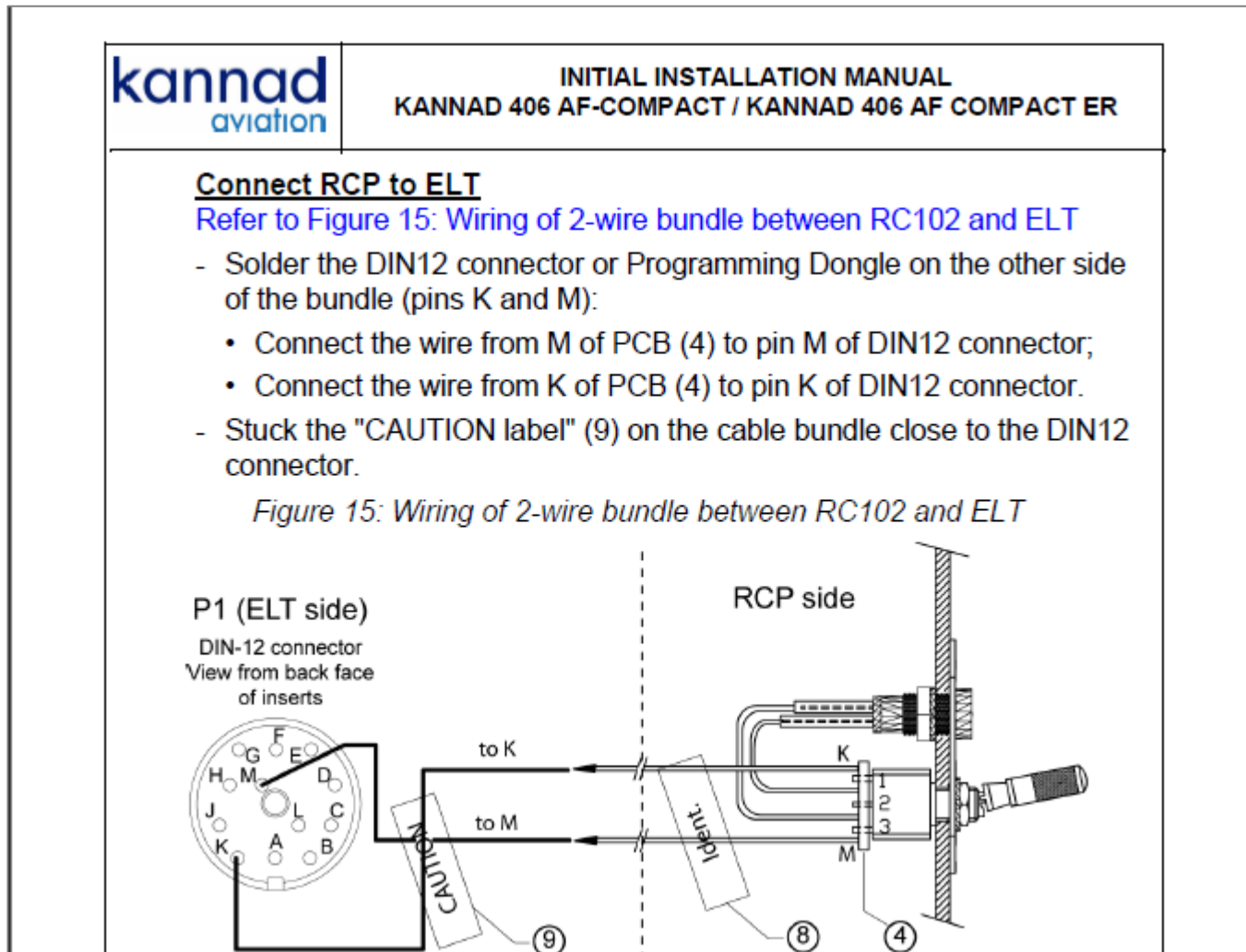

C. Wiring diagram with RC200 RCP**Connection**

Refer to Figure 17: Wiring of 3-wire bundle between RC200 and ELT.

Fabricate a 3-wire bundle (AWG 24, shielded preferred) long enough to reach between the ELT installation location and the cockpit RCP location.

Slide heat-shrinkable sleeves on both sides of each wire.

On the ELT side:

- Solder the wires to the DIN12 connector supplied with the pack:
  - solder the wires to pins G (RCP COMMON), A (RCP RESET) and J (RCP LED) of the connector.
  - Put heat-shrinkable sleeves to protect the pins

PAGE: 22

AUG 20/2013



INITIAL INSTALLATION MANUAL  
KANNAD 406 AF-COMPACT / KANNAD 406 AF COMPACT ER

On the RCP side:

- Strap pins 4 and 5 of the female 9-pin D-SUB connector supplied with the pack.
- Solder the wires to the female 9-pin D-SUB connector as follows:
  - Pin 8 (RCP COMMON) has to be connected to Pin G (RCP COMMON) of the ELT;
  - Pin 4 (RCP RESET) has to be connected to Pin A (RCP RESET) of the ELT;
  - Pin 9 (RCP LED) has to be connected to Pin J (RCP LED) of the ELT.
  - Put heat-shrinkable sleeves to protect the pins.
- Connect the female 9-pin D-SUB connector to the male 9-pin D-SUB socket of the RC200.

Figure 17: Wiring of 3-wire bundle between RC200 and ELT

